

**STURDY**

# Plastic 2 & 4 Wheeled Containers

## The complete solution for waste collection!

For functionality and durability, a STURDY 2 or 4 Wheeled Container is the number one choice.



- Available in 3 sizes; 140lt, 240lt & 330lt
- Manufactured to European Standards EN 840
- Easy to use and easy to manoeuvre
- Rubber-tyre wheels for silent movement
- The sloped lid allows rainwater to drain off
- All bins can be personalised as an optional extra

### PRODUCT CODES

140lt: 116-A 240lt: 117-A 330lt - CODE: 118 - A



Standard 1100lt



Standard 660lt

- Available in standard sizes 1100lt & 660lt
- Available in a range of standard colours
- Manufactured from high-density polyethylene
- Drain plug makes cleaning easy
- Handles allow for ease of movement
- Integrates with comb and DIN lifting systems
- EN 840 Certified by Lloyds of London
- Personalisation is available as an extra

### PRODUCT CODES

1100lt: 323 - A 660lt: 119-A

## Domestic and Commercial Containers

Domestic and Commercial waste containers are built to European Standard EN 840 with 1100 and 660 litre capacity

### STANDARD FEATURES

- Galvanised Steel Body
- Full section comb lifting bar
- Fully welded internal seams
- Danish manoeuvring handles
- Diamond key operated lid lock

### STANDARD SAFETY FEATURES

- Luminous safety chevrons to front of containers
- Safety operating instructions on both sides of the lid

### OPTIONAL FEATURES

- Hard wearing powder-coated finish in a range of colours
- Identification logos
- Security identification embossing on container body
- DIN lifting points
- Key operated central locking to front castors
- Spine type security lid lock
- Half-drop doors to front or back of container
- Power towing attachment
- Fork truck pockets to base of container

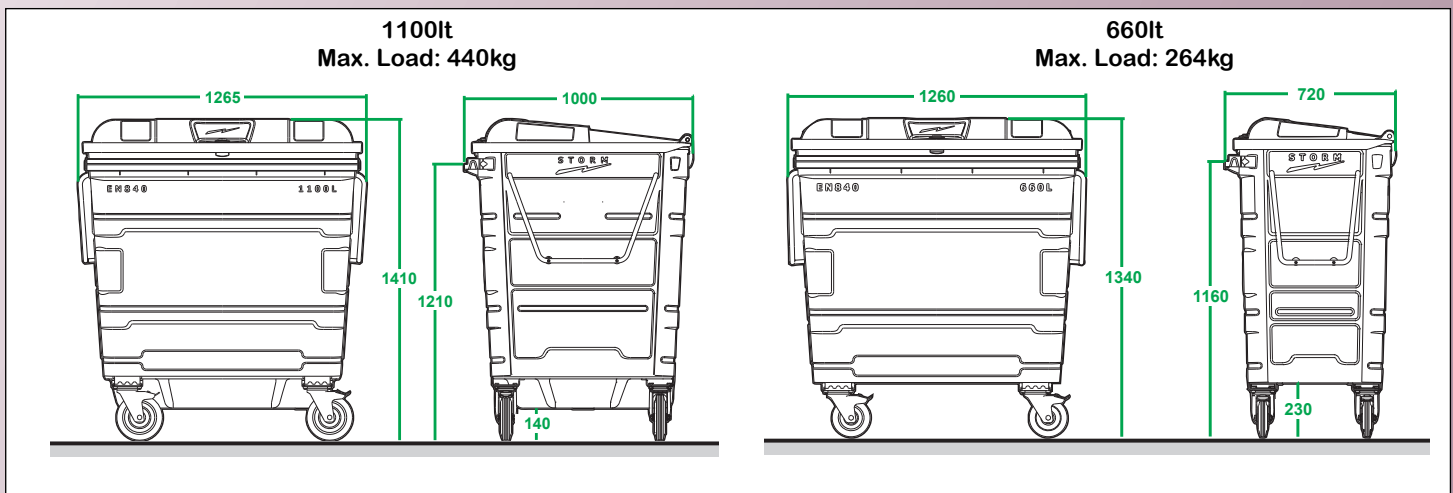

Note: The addition of DIN Points will add approx. 105mm to the width of each bin