

# STURDY 240lt 2 Wheeled Bin

## Functionality, durability and low noise!

STURDY 2 wheeled 240lt bins are the ideal solution for waste disposal and collection.



### Service Life:

Made from high density polyethylene, stabilised against UV degradation, is shock absorbent and resists many common chemicals and temperature extremes.

### Wheels:

Wheels with rubber tyres for smooth operation and can withstand the severest of usage. Replacing the wheels is rapid and easy.

### Ergonomic Lid:

Peripheral hand grip for easy opening.

### Fixings:

Strong connections between the lid and the body and the wheels and body.

### Safe Collection:

The reinforced flange ensures high reliability with regards to constraints caused by lifting / emptying operations.

### Permanently Identified:

Bins can be stamped with a unique serial number on either the lid or the body.

### Environment:

These products are manufactured in an ISO 4001 certified production unit.



## Product Specifications

### 240lt Bin Dimensions

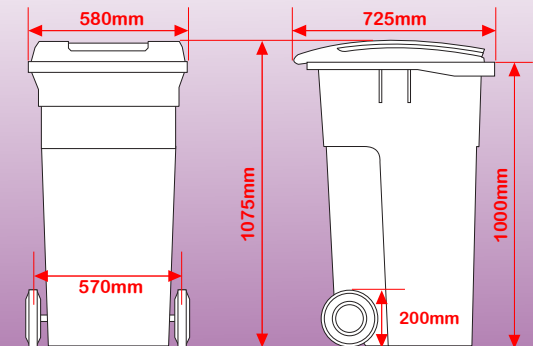

Weight: 13.5 kg's Payload: 100 kg's